

GS™ -4047

Specifications

MODELS		GS™-4047	
MEASUREMENTS		Metric	US
Working height maximum		13.94 m	45 ft 1 in
A	Platform height maximum	11.70 m	30 ft
B	Platform height stowed	1.43 m	4 ft 8 in
C	Platform length - outside	2.26 m	7 ft 5 in
	- extended	3.18 m	10 ft 5 in
Slide-out platform extension deck		0.91 m	3 ft
D	Platform width- outside	1.16 m	3 ft 10 in
Guardrail height		1.09 m	3 ft 7 in
Toeboard height		0.15 m	6 in
E	Height - stowed : folding guardrails	2.55 m	8 ft 4 in
	: rails folded	1.96 m	6 ft 5 in
F	Length - stowed	2.48 m	8 ft 2 in
	- extended	3.18 m	10 ft 10.5 in
G	Width	1.20 m	3 ft 11 in
H	Wheelbase	1.85 m	6 ft 1 in
I	Ground clearance - centre	0.10 m	4 in
J	-with pothole guards deployed	0.02 m	0.9 in

PRODUCTIVITY		
Maximum platform occupancy - indoor	3	3
- outdoor	1	1
Lift capacity	350 kg	770 lbs
Lift capacity - extension deck	113 kg	250 lbs
Drive speed - stowed	3.2 km/h	2.0 mph
Drive speed - raised	0.8 km/h	0.5 mph
Gradeability	25%	25%
Turning radius - inside	zero	zero
Turning radius - outside	2.31 m	7 ft 7 in
Raise/lower speed	71 / 41 sec	71 / 41 sec
Controls	proportional	
Drive	dual front wheel	
Multiple disc brakes	dual rear wheel	
Tyres - solid non-marking	38 x 13 cm	15 x 5 x in

POWER		
Power source	24 V DC (four 12 V 150 Ah batteries)	
Hydraulic system capacity	28.4 L	7.5 gal

WEIGHT		
	3,243 kg	7,149 lbs

STANDARDS COMPLIANCE ANSI A92.6, CSA B354.2, CE Compliance, AS 1418.10

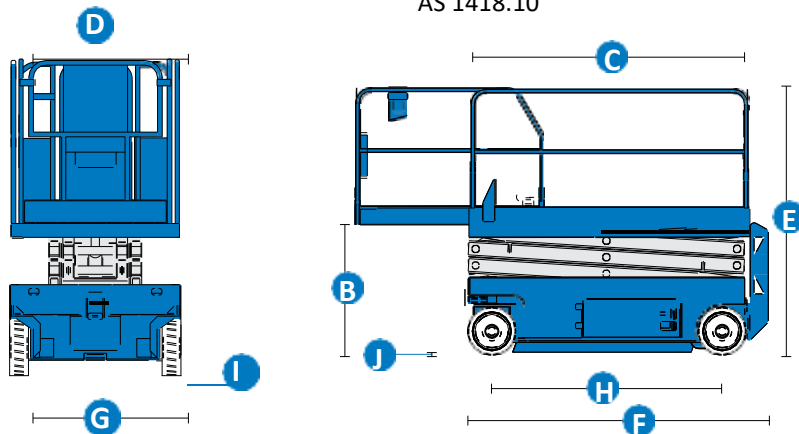

STANDARD FEATURES

- Folding rails with full height swing gate
- Dual front wheel drive
- Proportional lift and drive
- Platform control with battery charge indicator and diagnostic display
- Onboard diagnostic system
- Lanyard attachment points
- Manual platform lowering valve
- Emergency stop at both platform and ground controls
- Rear wheel multiple disc brakes
- Front wheel hydraulic dynamic braking
- Brake release
- Drive speed interlock
- Swing-out component tray
- Solid non-marking tyres
- Pothole guards
- Tilt alarm
- Descent alarm
- Electronic horn
- Hour meter
- Dual flashing beacons
- Motion alarm
- POWER**
- 24V DC (four 6V 225 Ah batteries)
- Universal 20 amp smart charger

